

50HZ 1/2HP OWNER'S MANUAL

MASTERS DECORATIVE SERIES

Every **AquaMaster®** unit is fully inspected and produced in accordance with applicable standards for safety, and are listed by Underwriters Laboratories, Inc. (UL) for safety in the USA and Canada. **AquaMaster®** will continue to build the best units to assure you, the customer, of many years of enjoyable and reliable service. AquaMaster's commitment to excellence ensures superior aquatic management systems.

WARNING



NOTICE: Save and pass the installation, anchoring and operating instructions to subsequent owners. The information provided is intended to notify and warn about making unsafe modifications, making unsafe repairs, or using unauthorized parts or repair facilities.

- Improper installation, operation, service, repair, maintenance or alteration of this product may result in property damage or bodily injury.
- Turn **OFF** electrical power at disconnect switch or service panel before servicing this unit or lighting system.
- Risk of electric shock! This pump or lighting system has not been investigated for use in swimming pool or marine areas. **DO NOT use in swimming or marine areas.**
- Only qualified personnel shall service and install **AquaMaster®** pumps or lighting systems. Installation and service to be in accordance with state and European community, national, local codes or ordinances. This unit is intended to be operated only after it is properly installed, anchored and wired.
- Risk of electrical shock! **DO NOT** operate this unit dry unless testing for proper rotational/mechanical function (see electrical connections, later in this manual). If this unit has been inadvertently operated out of the water, the unit must be serviced by a qualified person before being returned to service.
- Risk of electric shock! This pump and lighting system is supplied with a grounding conductor. To reduce the risk of electric shock, be certain that it is connected only to a proper ground. Use a copper conductor of the correct size from the grounding terminal in the control box to a grounding connection in the service panel.
- This pump and lighting fixtures are provided with flexible underwater cable and strain relief. **DO NOT** remove as electrical shock and/or damage to this unit or lighting system could occur.
- Risk of electrical shock! **DO NOT** remove the wire harness from the pump housing or underwater disconnect. **DO NOT** connect conduit to pump.
- This unit and lighting system is intended for water use only. **DO NOT** operate out of the water unless checking for proper mechanical/electrical function.
- Risk of electrical shock! Submerge lighting fixtures before turning on.
- This pump and lighting fixtures are for fresh water only. Temperature not to exceed 40 degree C.

TABLE OF CONTENTS

Assembly Instructions.....	4-8
Electrical Assembly Instructions	9-11
Digital Timer Operating Instructions.....	12
Anchoring Instructions.....	13-16
Maintenance.....	17
Winterization.....	18
Product Warranty.....	19
Underwater Night Glow Lighting System Warranty.....	20
General Warranty Information.....	20
Troubleshooting Guide.....	21
220 Volt Night Glow Lighting Break Down.....	22
AquaLock (ALC) Components View.....	23
Internal Fountain Components List.....	24
Internal Parts Drawing.....	25
Power Unit Parts Lists.....	26
Power Unit Drawing.....	27
Pushbutton RGBW Quick Start Program Guide (<i>if applicable</i>).....	29-33
Bluetooth Controller Manual (<i>if applicable</i>).....	35-47

SHIPPING CLAIMS

When you receive your **AquaMaster®** unit, examine the package for any signs of external damage it may have sustained enroute. If there is apparent damage either outside the box or to its contents, make a claim with the shipper immediately. Save the original shipping carton and the packing material if a claim is to be filed.

Pictures and images used in this manual are for representational purposes only, may not depict the actual product.

MASTERS DECORATIVE ASSEMBLY INSTRUCTIONS

WARNING: Read these instructions carefully. Failure to follow these instructions could cause a malfunction of the system. Improper installation, wiring or anchoring could result in property damage or bodily injury.



Carefully unpack your unit and inspect for damage.

Parts Included:

- 1 – Float
- 1 – Float Tube
- 1 – Intake Screen with Fasteners
(Nut, Washer and Bolt Included)
- 1 – Power Unit and Power Cord
- 1 – Parts Bag with 3/16" Allen Wrench
- 1 – Owners/Instruction Manual



FLOAT ASSEMBLY

1. Take O-ring, which was provided, and place on groove in float tube on under side of float. Apply silicone grease to float tube and O-ring, which was provided.
2. Place power unit/housing assembly over float tube. The alignment bolt head fits into groove on impeller housing.
3. Secure float tube to impeller housing with (4) stainless steel screws which have been provided.
4. Slide the float onto the float tube until it bottoms against the impeller housing. The float must be installed as shown with the inner ring toward the motor. Installing the float upside-down will adversely affect its performance.
5. Using the 3/16" Allen wrench, install four (4) of the 1/4-20 socket head cap screws into the upper float tube mounting holes. These holes are closest to the grooved end of the float tube. **DO NOT** over-tighten the screws.
6. Slide the float up until the socket head cap screws are seated in the slots on the top of the float.
7. Maintain this float position and install the two (2) remaining 1/4-20 socket head cap screws in the float tube found on the bottom of the float. **DO NOT** over-tighten the screws.

ASSEMBLY INSTRUCTIONS (CONT.)

SCREEN ASSEMBLY

CAUTION: DO NOT OPERATE WITHOUT THE SUCTION SCREEN IN PLACE.



1. Loosen and remove the nut, lock washer and bolt holding the screen closed. Save these parts for reuse once the screen is in place.
2. Gently flex open the intake screen far enough to fit around the float tube. After it is installed around the float and on top of the power unit, close the screen tabs and reassemble the bolt, lock washer and nut to retain the screen in its proper location.

NOZZLE ASSEMBLY (optional)

1. Check the nozzle thumbscrews to make sure that they are not extending beyond the inner mounting surface. If they are, back the thumbscrews out until the tips are flush with the inner mounting surface. This will allow for easy installation onto the float tube.
2. Install the O-ring (provided) into the top float tube groove. This may have been done at the factory.
3. Liberally apply grease (provided) to the inside of the nozzle mounting surface and the O-ring on the float tube.
4. Slide the open end of the nozzle over the float tube using a twisting and sliding motion until the nozzle is fully contacting the top of the float tube.
5. Carefully tighten the thumbscrews into the lower groove on the float tube. Using your hand, check that the nozzle is secure by pulling and twisting the nozzle. The nozzle should not move.

ASSEMBLY INSTRUCTIONS (CONT.)

AQUA LOCK (ALC) POWER CORD CONNECTOR

1. Locate the Female end of the ALC on the power cord. Remove the protective caps from the power cord and fountain. **Note: When your unit and/or lighting system requires removal, protective caps are provided to assist in maintaining a clean cable connector environment.** Simply hand-tighten one half to your power unit and the other half to your cable end. When you remove the protective caps, keep them in a safe place, such as the control panel.
2. Connect the two halves of the ALC together. **CAUTION: HAND TIGHTEN ONLY! DO NOT** use tools such as a pipe wrench or pliers as you may over tighten and damage the connectors.
3. Locate the cable support grip and clip it onto the snap clip located on the motor housing assembly clamp. This will protect your cord connectors from damage if the power cord is pulled.

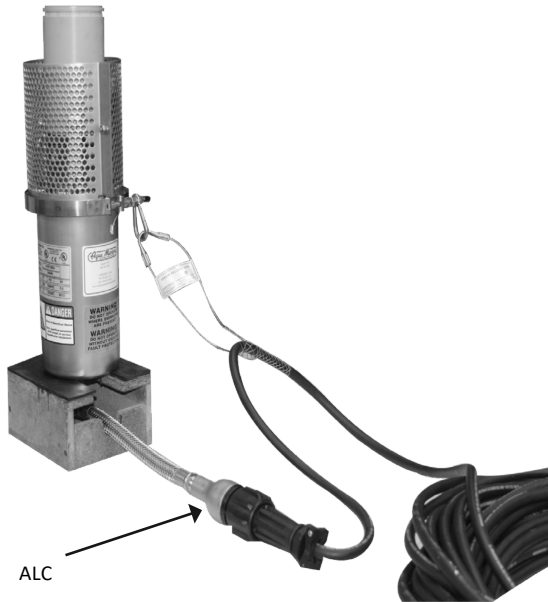

NIGHT GLOW LIGHTING SYSTEMS ASSEMBLY INSTRUCTIONS

1. Place light bracket in mating cavity on the underside of float as shown in Figure 1.
2. Insert 3/8" SS bolt through washer, through the float into light bracket as shown.
3. Secure the light bracket from the bottom with a 3/8" locking nut and washer.
4. Tighten the nut using (2) 9/16" wrenches or pliers. **DO NOT** over tighten.

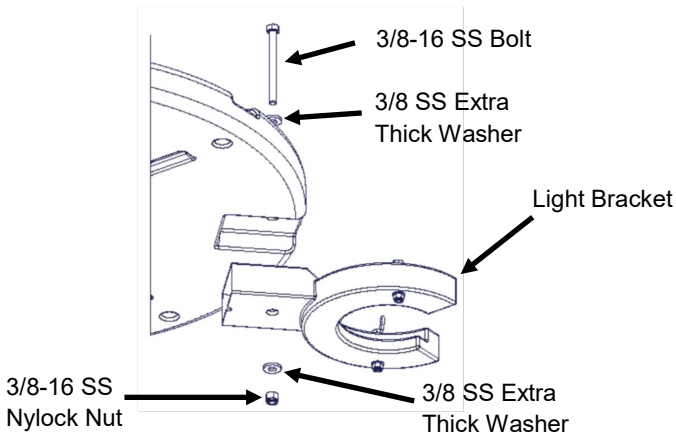
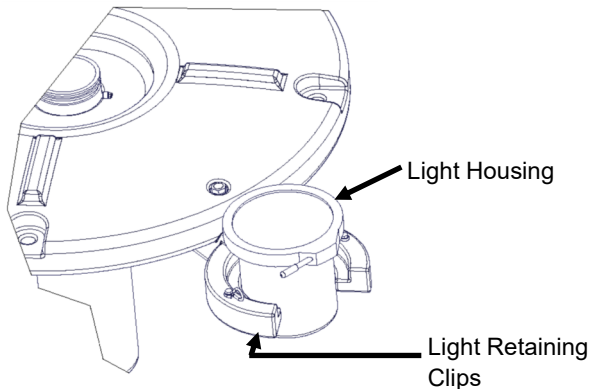

Figure 1

5. Make sure the light retaining clips are in the "open" position. The clips are positioned without the use of tools.
6. Insert the light housing from the top down as shown in Figure 2.



NIGHT GLOW LIGHTING SYSTEMS ASSEMBLY INSTRUCTIONS (CONT.)

7. When the light housing is seated into the bracket, turn the retaining clips to ensure the housing is as shown in Figure 3.

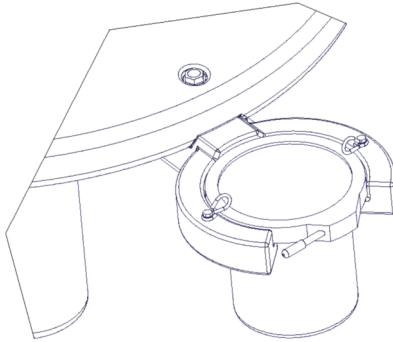

Figure 3

8. After fixtures are installed on the float, connect the AquaLock (ALC) ends together.
HAND TIGHTEN ONLY!

ELECTRICAL CONNECTION – 50Hz

(Electrical Control Panel NOT supplied by AquaMaster®)

Electrical connections must be completed by a licensed electrician or installer in accordance with European community, national, local codes or ordinances.

CAUTION: Aeration systems require the use of a residual current device (RCD) with a rated residual operating current not exceeding 30 mA for safe operation. If the proper grounding and RCD are not used, serious FATAL electrical shock may occur.



ELECTRICAL NOTICE

Supply conductors must be of sufficient cross sectional area to operate the equipment in regard to cable length, motor nameplate current and voltage ratings. All cables, conduits and external ducts must enter the enclosure from the bottom only. Install cables, conduits and external wiring ducts by qualified installer and per local codes utilizing appropriate bushings and glands. Care must be used to protect cables when entering and leaving the pond area by the use of protective duct, conduits or like protection devices. Electrical cable must extend completely onto shore to power source without breaks or splices. Underwater splices are dangerous and will void the warranty.



WARNING

BEFORE INSTALLING INTO THE WATER, test the unit briefly (30 seconds or less) to make sure it runs and check for proper rotation (counter clockwise looking down from top of power unit). Listen for any unusual noises. Unit should run smoothly and quietly. If single phase rotation is backwards, **PLEASE CONTACT THE FACTORY IMMEDIATELY**. If three phase rotation is backwards, change any two motor load leads. If rotation is still backwards check all connections or contact the factory for assistance.

DO NOT operate the unit out of the water except for testing and checking rotation (30 seconds or less). **DO NOT** attempt maintenance procedures or adjustments with unit in operation.

DO NOT burn the lighting fixtures out of the water except to test the lamps (60 seconds or less).

NOTE: Excessive buildup on the lenses may cause the lenses to crack, lamps to burn out and gaskets to fail. To maintain maximum light output and long lamp life, cleaning of the lenses may become necessary.

GROUNDING

Permanently ground this unit in accordance with European community, national, local codes or ordinances. Use a copper conductor of the correct size from the grounding terminal in the control box to a grounded connection in the service panel or a properly driven and electrically grounded ground rod.

OPERATING CONDITIONS

OPERATE UNIT ONLY IN FRESH WATER WITH WATER TEMPERATURE NOT EXCEEDING 40 degree C. DO NOT OPERATE IN SWIMMING AREAS.

ELECTRICAL CONNECTION – 50Hz **(Supplied with AquaMaster® control panel)**

Electrical Connection to be completed by licensed electrician in accordance with the National Electric Code and local codes or ordinances.

WARNING: This unit is pre-wired and is provided with a RCD for your safety and the safety of your equipment in the event of an electrical short, ground or equipment failure. **DO NOT** remove or modify the RCD. Removal or modifications could result in the danger of electrocution to any one, human or animal, in contact with the water.



- **DO NOT** bypass the supplied control panel. The control panel enclosure is rain-resistant and includes a RCD breaker and timer. Bypassing the control panel could result in electrocution to anyone, human or animal, in contact with the water.
- Underwater splices are dangerous and will void the warranty. Electrical cable(s) must extend completely onto shore to power source without breaks or splices.
- **TURN OFF** electrical power at fuse box or service panel before making any electrical connections.
- If supplied with a control panel, **DO NOT** bypass the control panel. The control panel enclosure is rain-right and includes a RCD breaker, timer, contactor and overload assembly. Bypassing the control panel could result in electrocution to anyone, human or animal, in contact with the water.

ELECTRICAL CONNECTION TO CONTROL PANEL



WARNING: Make sure power is **OFF!**

1. Take the electrical cable from your unit and securely fasten it to the control panel.
2. Connect **black lead** from cable to terminal marked 1T1 on terminal strip.
3. Connect **white lead** from cable to terminal marked 1T2 on terminal strip.
4. Connect **green lead** to grounding terminal.

ELECTRICAL CONNECTION – 50Hz (CONT.) (Supplied with AquaMaster® control panel)

Steps A – D are for optional LED lighting system.

- a. Take the three (3) conductor cable for the lighting system and securely fasten it to the control panel.
- b. Connect **black lead** from cable to terminal marked X1 on terminal strip.
- c. Connect **white lead** from cable to terminal marked X2 on terminal strip.
- d. Connect **green lead** to grounding terminal.

Steps E – J are for optional LED RGBW lighting system.

- e. Take the five (5) conductor cable for the lighting system and securely fasten it to the control panel.
- f. Connect **black lead** from cable to terminal marked X1 on terminal strip.
- g. Connect **white lead** from cable to terminal marked X2 on terminal strip.
- h. Connect **green lead** to grounding terminal.
- i. Connect **orange lead** from cable to terminal marked X4 on terminal strip.
- h. Connect **red lead** from cable to terminal marked X5 on terminal strip.

WARNING: Make sure power is **OFF!**



1. Connect **Line 1 to L1** on terminal strip.
2. Connect **Line 2 to L2** on terminal strip (208-240V only).
3. Connect the **neutral to N** on terminal strip.
4. Connect the **ground to the grounding** terminal.
5. On 208-240V units, the overload relay must be set to the motor nameplate value plus two (2) amperes.

BEFORE INSTALLING INTO THE WATER, test the unit briefly (30 seconds or less) to make sure it runs and check for proper rotation (counter clockwise looking down from top of power unit). Listen for any unusual noises. Unit should run smoothly and quietly. If single phase rotation is backwards, **PLEASE CONTACT THE FACTORY IMMEDIATELY.**

WARNING: DO NOT operate the unit out of the water except for testing and checking rotation (30 seconds or less). **DO NOT** attempt maintenance procedures or adjustments with unit in operation.

WARNING: DO NOT burn the lighting fixtures out of the water except to test the lamps (60 seconds or less).

NOTE: Excessive buildup on the lenses may cause the lenses to crack, lamps to burn out and gaskets to fail. To maintain maximum light output and long lamp life, cleaning of the lenses may become necessary.

GROUNDING

Permanently ground this unit in accordance with the National Electric Code and local codes or ordinances. Use a copper conductor of the correct size from the grounding terminal in the control box to a grounded connection in the service panel or a properly driven and electrically grounded ground rod.

TIMER OPERATING INSTRUCTIONS

1. To set the time, hold down the CLOCK Key while pressing either the HOUR or MINUTE keys. Continue pressing until the desired number is shown. Then simply lift finger off the CLOCK Key to set.
2. To Set Program (ON/OFF) times: Press the TIMER Key once to enter into program mode. Display will show "1 ON-- --".
3. Press the HOUR Key and then the MINUTE Key to select the desired first OFF time. Repeat the entire sequence to complete up to eight ON/OFF times as desired.
4. When programming is done, press the CLOCK Key then the SELECT Key repeatedly until the indicator bar is above the word "AUTO".

CAUTION: Disconnect all power before servicing. **DO NOT** install or operate in swimming areas.

OPERATING CONDITIONS



OPERATE UNIT ONLY IN FRESH WATER WITH WATER TEMPERATURE NOT EXCEEDING 40° C. DO NOT OPERATE IN SWIMMING AREAS.

1. Make sure the timer is set to the proper time on the front dial of the timer. Set the on-off sequence to turn the fountains on and off at the desired time.
2. Turn on supply disconnect which is located on the right side of the panel.
3. Turn on the Residual Current Operator. Test to make sure that this safety device works properly. Press the test button and the breaker should trip. If it does not trip, check for proper wiring or defective device.

NOTE: DO NOT BYPASS THIS SAFETY DEVICE. THIS DEVICE MUST BE TESTED EVERY MONTH.

4. Reset the breaker.
5. Sit back and enjoy your fountain/aerator.

CAUTION: DISCONNECT ALL POWER BEFORE SERVICING



ANCHORING INSTRUCTIONS

CAUTION: If the unit is not properly anchored with adequate tension, the unit will rotate when in operation, resulting in twisted and damaged electrical cable(s).



FIGURE 1 is most applicable for a smaller pond, or one that is easily accessible from two sides.



Required Equipment (not provided)

- Two (2) anchor lines (1/4 inch nylon, 1/8" stainless steel cable, or equivalent).
- Two (2) stakes (wood stake or metal rod that can be driven securely into pond's edge).

Anchoring Steps

1. With the unit fully assembled and still on shore, attach anchor lines to the float. Only use the anchor holes which are opposite from one another. Next, carefully lower unit into the pond. **DO NOT** tangle anchor lines and electrical cable(s).
2. Once the unit is floating freely hold or secure one anchor line. With second line, walk slowly away from the first stake to opposite side of pond, pulling the unit with you. Continue until unit is in desired location.
3. Secure all lines, keeping tension on all. Make sure electrical cable(s) is untangled and has some slack from unit to shore.

ANCHORING INSTRUCTIONS (CONT.)

CAUTION: If the unit is not properly anchored with adequate tension, the unit will rotate when in operation, resulting in twisted and damaged electrical cable(s).



In a larger body of water or where vandalism is a concern, **FIGURE 2** is the preferred method.

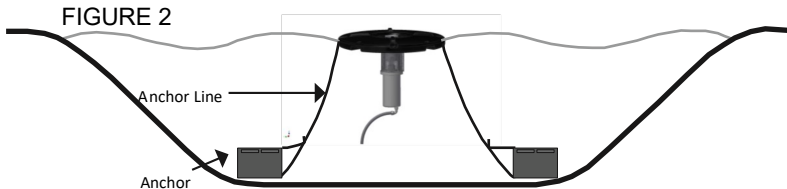

Required Equipment (not provided)

- Two (2) anchor lines (1/4 inch nylon, 1/8" stainless steel cable or equivalent). Anchor line length should equal twice the depth of the pond at point of installation. (Example, if pond depth is eight feet, each anchor line should be at least sixteen feet.) **If the depth of the pond varies more than three feet use FIGURE 1.**
- Two (2) anchors (eight inch concrete blocks, approximate weight of 30 pounds each is sufficient).

Anchoring Steps

1. With unit fully assembled and still on shore, attach anchor lines to the float. Only use the anchor holes which are opposite from one another. Next, carefully lower unit into the pond. **DO NOT** tangle anchor lines and electrical cable(s).
2. Position unit at desired location in pond, playing out electrical cable(s) from shore. Attach anchor lines to anchors and anchor unit making sure you cannot rotate unit more than 45 degrees. Some movement is necessary to allow float to move up and down with changes in water depth. **If you can rotate float more than 45 degrees, adjust anchor lines or relocate anchors.**

FOUR-POINT ANCHORING

At times, because of pond depth, pattern, or pond size, four-point anchoring may become necessary or desirable to prevent your unit from rocking.

1. Below is a drawing that depicts the manner in which the anchors are to be deployed.
2. You will need to pick four anchor points on the float and secure your anchor lines to these points.
3. About 10 to 15 feet from your anchor points on your float, intermediate weights of approximately 5 lbs. each should be secured to your anchor lines. These weights will keep tension on your anchor lines even though the water depth may vary.
4. Stretch out your anchor lines so your intermediate weights are suspended in the water and not sitting on the bottom. When the anchor lines are properly stretched out, fasten them securely to your anchors on shore or the bottom as required.

CAUTION: If the unit is not properly anchored with adequate attention, the unit will rotate when in operation, resulting in twisted and damaged electrical cable(s).

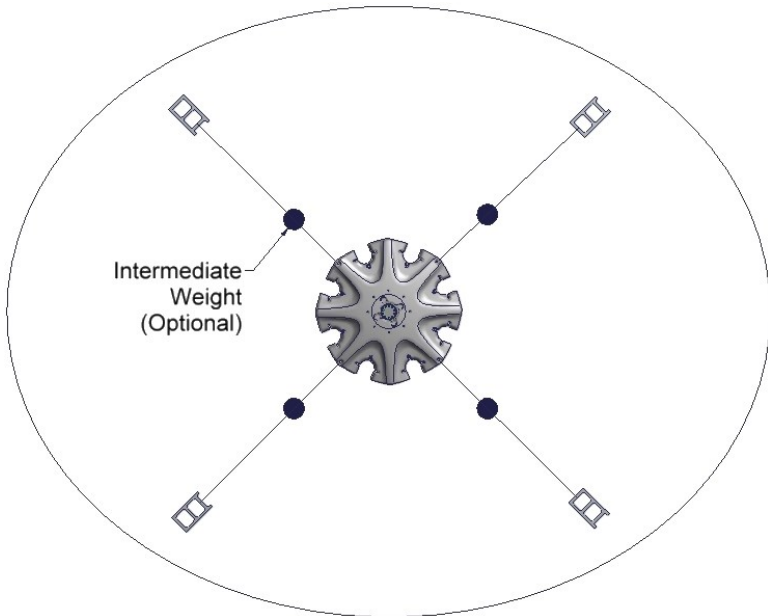

ANCHORING INSTRUCTIONS (CONT.)

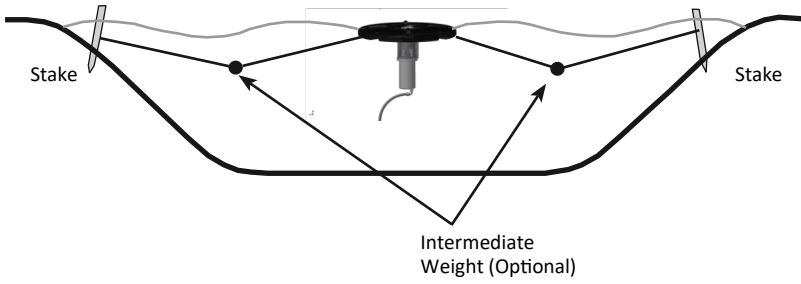

Intermediate weights can also be used with all kinds of anchoring to keep constant tension on the anchor lines when the pond depth varies. Follow the installation instructions from the previous page.

MAINTENANCE



WARNING: DISCONNECT ALL POWER BEFORE SERVICING

Like all pieces of precision machinery, certain maintenance procedures must be performed to keep the unit running trouble free for years. The following recommendations should be done annually to prevent a more serious and costly problem from occurring.

Following these recommended procedures will result in years of trouble free operation, as well as keeping the warranty in effect.

- In all cases it is strongly recommended that the unit is removed from the water annually for a good visual inspection.
- Remove the unit from the water and inspect the nuts, bolts, brackets and float. Replace any broken or worn parts. Tighten any nuts and bolts that may have worked loose.
- Make sure the intake screen is in place, intact and free of debris. If debris is floating in the water (plastic bags, fishing line, etc.), performing routine maintenance more frequently on the unit will help assure years of trouble free operation.
- Inspect the motor shaft, propeller and diffuser making sure they are not damaged. If there is damage to any parts, replace them. If debris has wrapped around them, remove it, and inspect the shaft especially around the seal area. Debris wrapped in this area can push the seal faces apart causing water to enter the unit and shorting out the motor. If there is any evidence of this an annual maintenance should be performed (oil and seal change) to keep the unit running properly and warranty in effect.
- Check motor bearings by turning the propeller shaft by hand; it should turn smoothly and quietly.
- Inspect the power cable making sure there are no cuts, worn spots or animal chew marks. If any damage has occurred, replacement of the cable must be done, do not splice your cables. Make sure the cable support grip is not broken and securely fastened to the unit before putting the unit back into the water.
- Under normal conditions, internal maintenance is not required for a specific period of time after the initial installation of the unit. Routine maintenance consisting of power unit oil and seal change, along with inspection of all other in-water and electrical control panel components is recommended annually when installed in saltwater or highly brackish water conditions. Preventative or routine maintenance expenses are the responsibility of the customer. For warranty repair or replacement consideration, equipment must be pre-approved and returned to the **AquaMaster®** factory for inspection, repair or replacement.
- On 1-5HP units it is recommended that maintenance of replacing the seal and oil be performed annually after the initial 5 years of operation and every year thereafter.

For further information, parts ordering assistance and the name of the closest distributor contact the factory at 920.693.3121.

WINTERIZATION

AquaMaster® strongly suggests removing the unit for winter if you experience long periods of cold, freezing weather. Damage to the float, lighting, and power unit could result from ice around the unit or lighting system. Also, possible damage to the motor could result if the propeller or impeller is frozen in the ice when the unit tries to start.

There are specific maintenance procedures, as outlined in these assembly instructions, that will keep your unit trouble free for years. These procedures are especially important should you live in a potentially cold climate. The removal of your **AquaMaster®** unit before freezing conditions occur is a perfect opportunity to inspect your unit and keep it running trouble free.

If you have freezing temperatures for short periods of time, you can decrease the chance of freezing by running the unit for 24 hours a day.

NOTICE: Freeze damage to any component of your **AquaMaster®** unit or lighting system will not be covered under warranty.

WARNING: When operating the unit in ice covered bodies of water, the ice around the open water will be dangerously thinner than the rest of the body of water. Signs such as **DANGER THIN ICE** need to be posted. Injury and/or fatality may result if this danger is not posted. **Owner assumes all responsibility.**



**MASTERS DECORATIVE SERIES
IN-WATER COMPONENTS PRODUCT WARRANTY (LIMITED)**

AQUAMASTER®, hereinafter referred to as The Seller, warrants your Series 304 and/or Series 316 Stainless Steel motor and seal assembly, float and underwater power cable (referred to as in-water components) for a period of 3 years on parts and 1 year on labor with the upgraded control panel, **when used in fresh water only**. This coverage is at 100% replacement costs, should it fail due to defects in materials or workmanship, during the 3 year on parts and 1 year on labor period. This is in effect from the date of shipment, when given normal and proper usage as determined by The Seller or its authorized representative upon examination, and when owned by the original user. **Please note that normal and proper usage does not include any salt water or highly brackish water conditions. Series 316 Stainless Steel units must be used for these conditions.**

**SERIES 316 STAINLESS STEEL
IN-WATER COMPONENTS PRODUCT WARRANTY**

The Seller warrants your Series 316 Stainless Steel in-water components for a period of 3 years on parts and 1 year on labor, when operating in any salt water or highly brackish water conditions. This coverage is at 100% replacement costs, should it fail due to defects in materials or workmanship, during the 3 year parts and 1 year labor period. This is in effect from the date of shipment, when given normal and proper usage as determined by The Seller or its authorized representative upon examination, and when owned by the original user.

**ELECTRICAL CONTROL PANEL AND
THEIR COMPONENTS PRODUCT WARRANTY**

The Seller warrants all parts of its electrical control panel and their components against defects in material or workmanship for a period of 3 years on parts and 1 year on labor from date of shipment when given normal and proper usage as determined by The Seller upon examination, and when owned by the original user. Components purchased by The Seller as complete units and used as an integral part of The Seller's equipment will be covered by the standard warranty of the manufacturer thereof. The Seller will repair or replace F.O.B. original shipping point (but not install) any part or parts of its manufacture which in its judgment shall disclose defects in either material or workmanship. If requested by The Seller, parts for which a warranty claim is made are to be returned transportation prepaid to our Factory. This warranty becomes void if the article claimed to be defective has been repaired or altered in any way, or if the unit has been subject to misuse, negligence or accident, or when instructions for installing or operating have been disregarded.

It is recommended that the enclosed warranty card is returned to The Seller. A return authorization number must be obtained prior to any required return. We make no other warranty, expressed or implied, and make no warranty of merchantability or of fitness for any particular purposes, and there are no warranties which extend beyond the description of the face hereof. No employee or representative is authorized to change this warranty in any way or grant any other warranty. The remedies hereinabove afforded to original user are exclusive of all other remedies provided by law. The Seller shall not be liable for indirect or consequential damages where the loss sustained is of a commercial nature.

UNDERWATER NIGHT GLOW LIGHTING SYSTEM IN-WATER COMPONENTS PRODUCT WARRANTY

AQUAMASTER®, hereinafter referred to as the seller, warrants all products and parts of its own manufacture against defects in material or workmanship for a period of 3 years on parts and labor, 3 years on LED lamps from date of shipment when given normal and proper usage as determined by seller upon examination, and when owned by the original user, **when used in fresh water only or if purchased Series 316 Stainless Steel to operate in any salt water or highly brackish water conditions.** Components purchased by seller as complete units and used as an integral part of sellers equipment will be covered by the standard warranty of the manufacturer thereof. Seller will repair or replace F.O.B. original shipping point (but not install) any part or parts of its manufacture which in its judgment, shall disclose defects in either material or workmanship. If requested by seller, parts for which a warranty claim is made are to be returned transportation prepaid to our factory. Expressly excluded from this warranty are replacement light bulbs, which are normal wear and replacement items. This warranty becomes void if article claimed to be defective has been repaired or altered in any way or when the article has been subject to misuse, negligence or accident, or when instructions for installing or operation have been disregarded. This coverage is at 100% replacement costs, should it fail due to defects in materials or workmanship, during the 3 year period, halogen lamps have no warranty. This is in effect from the date of shipment, when given normal and proper usage as determined by The Seller or its authorized representative upon examination, and when owned by the original user. **Please note that normal and proper usage does not include any salt water or highly brackish water conditions. Series 316 Stainless Steel units must be used for these conditions.**

GENERAL WARRANTY INFORMATION

AquaMaster® products and their accessories are warranted against defects in material and workmanship. The warranty period commences on the date the unit is installed as shown on the warranty registration card that must be returned to **AquaMaster®**. If no card has been returned, the warranty commences on the date the unit was shipped from our factory.

During the warranty period, **AquaMaster®** will repair or, at our discretion replace at no charge, all defective components provided the product is returned, shipping prepaid, to the **AquaMaster®** Service Department.

All warranty claims require prior Factory approval and authorization for return or service. Any and all warranty service work must be performed by **Aquamaster®** or approved Factory Trained Authorized Service Centers. Any type of service and repair performed within the warranty period by unauthorized personnel will void the warranty. Before returning a unit to the factory for repair, a Return Goods Authorization Number must be obtained. You can receive a number by calling the factory during normal business hours of 7:00 a.m. to 4:30 p.m. Central Standard Time at 920-693-3121.

If after inspection of a unit sent in for repair no problem is found, a standard service fee may apply.

TROUBLESHOOTING GUIDE

WARNING: Turn off all electrical power before servicing the unit.

To prevent accidental startup of the unit while repairs are in process or while servicing the unit, the main electrical equipment disconnect should be turned off and the panel should be locked out.



Symptom	Possible Cause	Solution
The unit will not operate.	There is no electrical power.	Check the breakers or fuses at the power source. Check the breakers and fuses in the control panel. Check the connections in the cord/motor disconnect. Check for the proper voltage.
	The motor hums but will not run.	Check the capacitors.
	GFCI tripped.	Reset the GFCI. If the GFCI continues to trip, have a qualified electrician check to determine the cause. Check the power cable for bite or chew marks (animal damage). Check the power cable cuts. If cut or damaged, replace the cable.
	The timer is not correct.	Reset the timer. This should be done after any power interruption. Check the voltage to the timer.
The motor runs but there is no spray pattern or the pattern is erratic.	The propeller is loose or missing. The propeller is bent.	Tighten or replace the propeller assembly. Replace the propeller diffuser assembly.
	Debris in the propeller diffuser assembly	Clean the debris out. NOTE: Plastic bags, plastic wrap on the propeller or shaft. This must be cleaned out for proper performance.
	The nozzle is clogged. The propeller is bent.	Remove the nozzle and clean out the debris. NOTE: If the water is very dirty, put on an oversized intake screen.
	The unit is touching the bottom of the water.	Reposition the unit to a deeper point in the water.
	High Winds.	No corrective action to be taken. The pattern will return to normal as the winds subside.
	Sinking float.	Replace the float.
The timer will not run.	Blown fuse.	Replace the control fuse.
	Bad timer.	Replace the timer.
The timer runs and the power are okay but the unit will not run.	Bad timer contacts.	Replace the timer.
The contactor is not good.	Overload tripped.	Reset the overload.
	Contactor is defective.	Replace the motor contactor.
The unit runs but stops and starts by itself.	Low oil in the unit.	Consult a dealer or authorized repair center.
	Leaky seal or damaged cable connector.	Consult a dealer or authorized repair center.

120 VOLT NIGHT GLOW LIGHTING

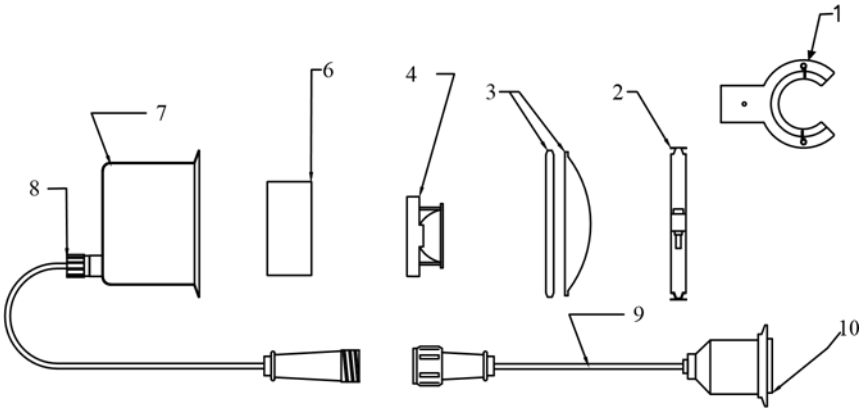

Item	Description	Part Number	
		11 Watt LED	20 Watt RGBW LED
1	Light Bracket Assembly	920028	920028
2	Clamp	880004	880004
3	Clear Lens and Gasket Assembly	761079	761079
4	Light Plate Assembly	CBA11-*	761042
5	Potting Resin	880128	880128
6	Power Supply Kit	880186	N/A
7a	Housing Single	880044	880044
7b	Housing Double	880045	880045
8	Cord Connector	860016	860015
9	ALC Assembly	760512-SS	760975
10	Kit - O-Ring & Wire Nut	760830	761087

* Select a Board color: Amber, Blue, Green, Red, White

NOTE: Lighting fixtures with LED lamps must be returned to **AquaMaster®** for service. There are no field serviceable components inside the fixtures.

MATCHING WIRE COLOR TO PIN LOCATION FOR AQUALOCK (ALC)

USE FOR DIAGNOSTIC PURPOSES ONLY

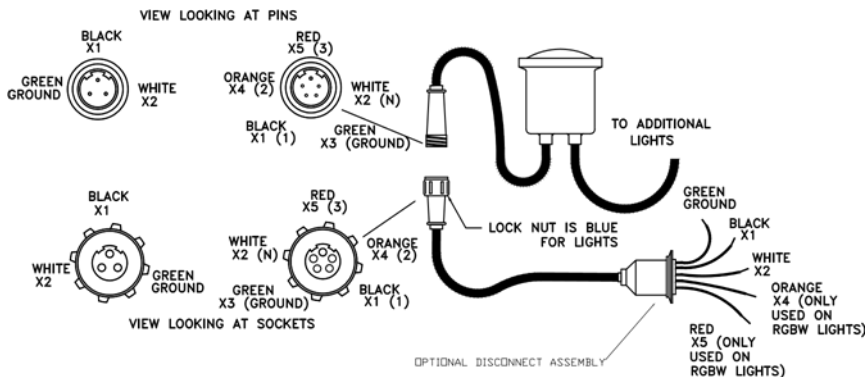
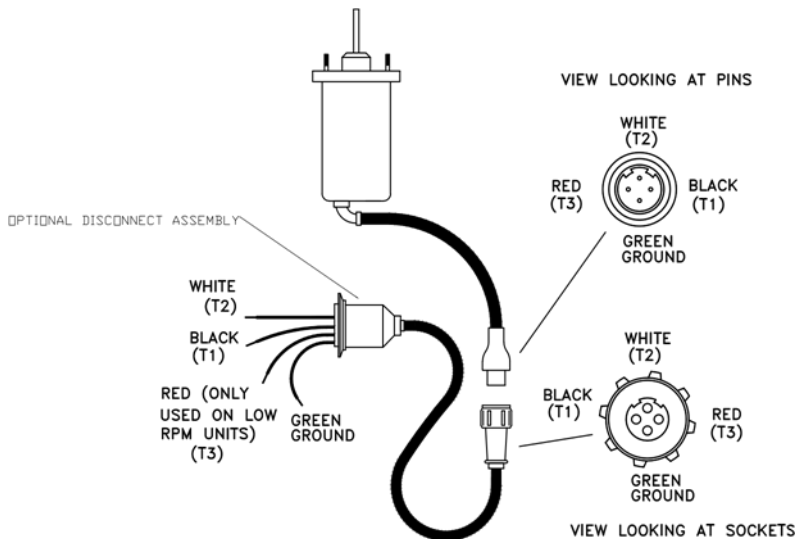

MD001-608

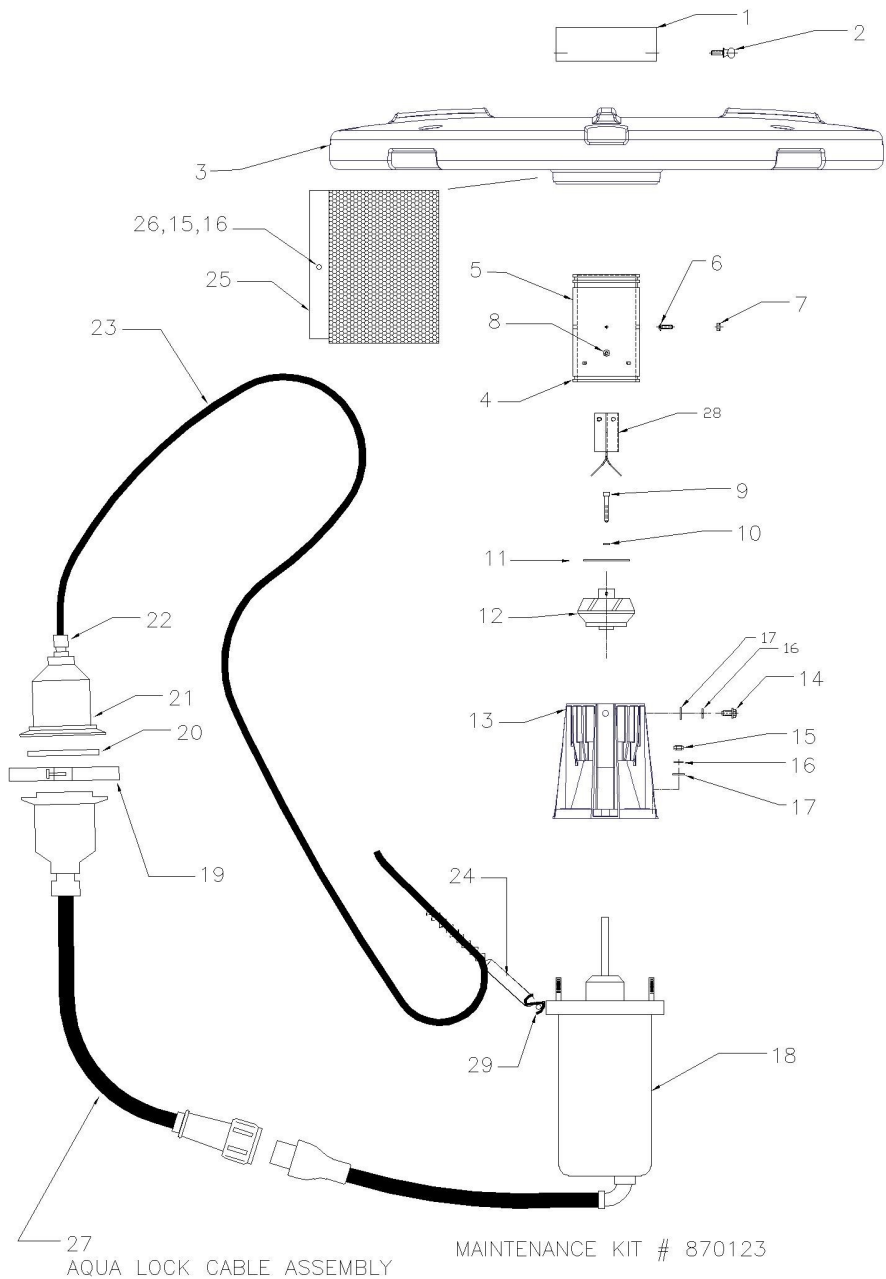

ITEM	QTY	PART NUMBER	DESCRIPTION
1	1	VARIES	NOZZLE
2	4	790236	SS THUMB SCREW
3	1	920001	FLOAT
4	2	810037	O-RING
5	1	920031	FLOAT TUBE
6	4	790071	SS FLAT HEAD SCREW
7	4	790052	NYLOCK NUT
8	7	790217	SS SOCKET HEAD SCREW
9	1	790074	SS IMPELLER BOLT
10	1	790049	SS LOCK WASHER
11	1	820198	DIFFUSER-LAKEWOOD PATTERN ONLY
12	1	820182	IMPELLER
13	1	820440	IMPELLER HOUSING
14	4	790107	SS BOLT
15	5	790087	SS NUT
16	9	790084	SS LOCK WASHER
17	8	790085	SS FLAT WASHER
18	1	760003	POWER UNIT-120V 60HZ
		760151	POWER UNIT-240V 60HZ
		760002	POWER UNIT-220V 50HZ
19	1	810033	DISCONNECT CLAMP
20	1	810032	DISCONNECT O-RING
21	1	880046	CABLE DISCONNECT BODY
22	1	860015	CORD CONNECTOR
23	X	VARIES	CABLE
24	1	860002	CABLE SUPPORT GRIP
25	1	820188	INTAKE SCREEN
26	1	790106	SS BOLT
27	1	760498	AQUA LOCK CABLE ASSEMBLY
28	1	820044	FLOW STRAIGHTENER KIT OPTIONAL
29	1	790445	SS SPRING CLIP

NOTE: FLOW STRAIGHTENERS ONLY USED
WITH NOZZLES WHICH REQUIRE THEM

NOTE:

WHEN ORDERING STAINLESS PARTS FOR SALTWATER OR
FOR CORROSIVE ENVIRONMENTS, PLEASE FOLLOW THE
PART NUMBER WITH -316. EXAMPLE: ITEM 19
WOULD BE 810033-316.

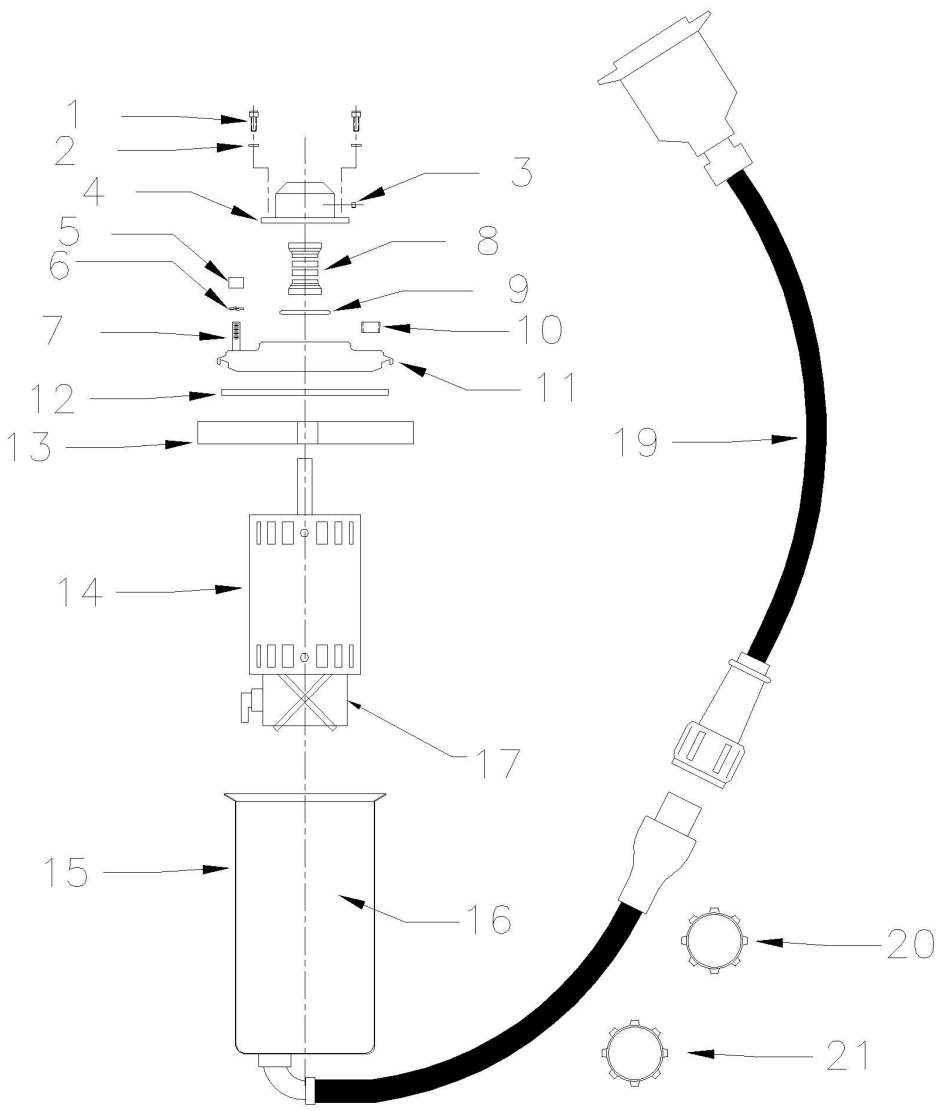

ITEM	QTY	PART NUMBER	DESCRIPTION
1	4	790065	#10-24 SOCKET HD SCREW
2	4	790050	#10 LOCK WASHER
3	1	790013	OIL PIPE PLUG
4	1	910034	SEAL CARTRIDGE
5	4	790087	1/4-20 SS NUT
6	4	790084	1/4" SS LOCKWASHER
7	4	790252	1/4-20 SS STUD
8	1	910040	SEAL ASSEMBLY
9	1	800051	O-RING, SEAL CARTRIDGE
10	1	790005	OIL FILL PLUG
11	1	910033	TOP PLATE, STAINLESS
12	1	830068	O-RING, TOP PLATE
13	1	880004	CLAMP RING
14	1	830075	MOTOR
15	1	760810	MOTOR HOUSING
16	1	QT. 870001	OIL, FOOD GRADE
17	1	800064	CAPACITOR
19	1	760498	AQUA LOCK CABLE ASSEM.
20	1	810083	SEALING CAP, POWER UNIT
21	1	810082	SEALING CAP, CABLE

NOTE:

WHEN ORDERING STAINLESS PARTS FOR SALTWATER OR FOR CORROSIVE ENVIRONMENTS, PLEASE FOLLOW THE PART NUMBER WITH -316. EXAMPLE: ITEM 13 WOULD BE 880004-316.

MAINTENANCE KIT # 870123

SEAL INSTALLATION TOOL #870005

Pushbutton RGBW Quick Start Program Guide

3000989

RGBW Controller Quick Start Guide - New Controller

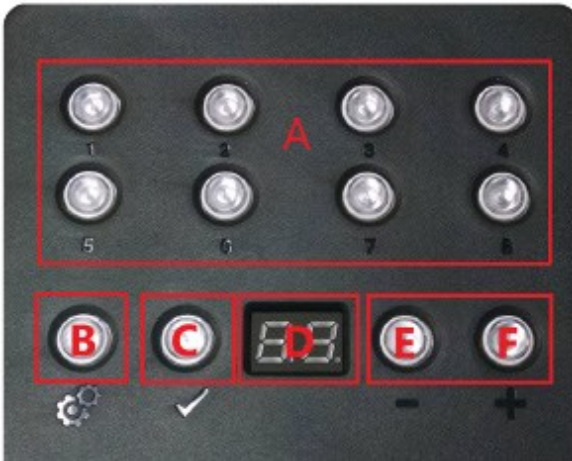

To Change Programs:

1. If not in scene mode, press the select button (B) until 'SA' appears in the LED display, and press the check button (C) to confirm.
2. Select programs 1-8 directly using the numbered push buttons (A).
3. Use the plus (F) and minus (E) buttons to select a program number, and press the check button to confirm.

To Change Program Speed:

1. If not in speed mode, press the select button (B) until 'SP' appears in the display (D), and press the check button (C) to confirm.
2. Use the '+' and '-' buttons to increase or decrease speed, and press the check button (C) to confirm.

To Change Program Brightness:

1. If not in dimming mode, press the select button (B) until 'dI' appears in the display (D), and press the check button (C) to confirm.
2. Use the plus (F) and minus (E) buttons to increase or decrease speed, and press the check button (C) to confirm.

NOTE: Decreasing brightness dims all lights, and increasing brightness turns up the white component of the RGBW light.

3000989

RGBW Controller Quick Start Guide - Old Controller

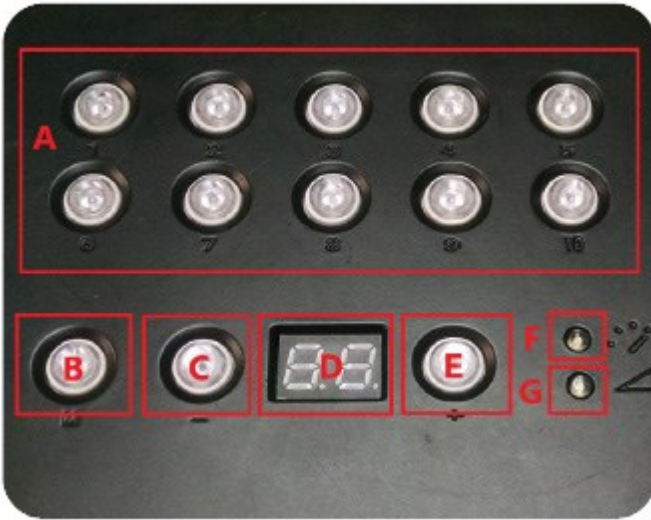

To Change Programs:

1. Select programs 1-10 directly by pressing any of the numbered buttons (A).
2. Use the plus (E) and minus (C) buttons to cycle through the programs. Upon reaching the desired program, hold down the plus (E) or minus (C) button. The program number will flash in the LED display (D) when it is selected.

To Change Program Speed:

1. Press the mode button (B) until the speed indicator lights up (F).
2. Use the plus (E) and minus (C) buttons to increase or decrease speed.

To Change Brightness:

1. Press the mode button (B) until the brightness indicator lights up (G).
2. Use the plus (E) and minus (C) buttons to increase or decrease brightness.

NOTE: Decreasing brightness dims all lights, and increasing brightness turns up the white component of the RGBW light.

3000989

RGBW Program List and Custom Programs

Program List:

- | | |
|----------------------------|-----------------|
| 1. White | 15. Cool Colors |
| 2. New Year's Day | 16. RGBW |
| 3. Valentine's Day | 17. CMYW |
| 4. Mardi Gras | 18. Red |
| 5. St Patrick's Day | 19. Orange |
| 6. 4th of July | 20. Yellow |
| 7. Breast Cancer Awareness | 21. Lime |
| 8. Thanksgiving | 22. Green |
| 9. Hanukkah | 23. Teal |
| 10. Christmas | 24. Cyan |
| 11. 12 Color Fade | 25. Indigo |
| 12. Rainbow | 26. Blue |
| 13. Pastel Rainbow | 27. Violet |
| 14. Warm Colors | 28. Magenta |
| | 29. Pink |
| | 30. Black (Off) |

Custom Programs:

- | | |
|----------------------------|-----------------|
| 1. White | 16. RGBW |
| 2. New Year's Day | 17. CMYW |
| 3. Valentine's Day | 18. Red |
| 4. Mardi Gras | 19. Orange |
| 5. St Patrick's Day | 20. Yellow |
| 6. 4th of July | 21. Lime |
| 7. Breast Cancer Awareness | 22. Green |
| 8. Thanksgiving | 23. Teal |
| 9. Hanukkah | 24. Cyan |
| 10. Christmas | 25. Indigo |
| 11. 12 Color Fade | 26. Blue |
| 12. Rainbow | 27. Violet |
| 13. Pastel Rainbow | 28. Magenta |
| 14. Warm Colors | 29. Pink |
| 15. Cool Colors | 30. Black (Off) |

3000989

RGBW Program Guide

New Years: Different intensities of white blinking and flashing.

Valentine's Day: Reds, pinks and whites chasing around.

Mardi Gras: Yellow, teal and magenta fading together.

St Patrick's Day: Light and dark shades of green chasing around.

4th of July: Red, white and blue fading together.

Breast Cancer Awareness: Pink.

Thanksgiving: Autumn colors of yellow, red, brown, and orange chasing around.

Hanukkah: Blues and silvers fading together.

Christmas: Red, white and green fading together.

12 Color Fade: 12 colors around the color wheel fading together.

Rainbow: 12 colors around the color wheel chasing.

Pastel Rainbow: 12 colors around the color wheel with a white element chasing.

Warm Colors: Red, orange and yellow fading together.

Cool Colors: Blues and greens fading together.

RGBW: Red, green, blue and white fading together.

CMYW: Cyan, magenta, yellow and white fading together.

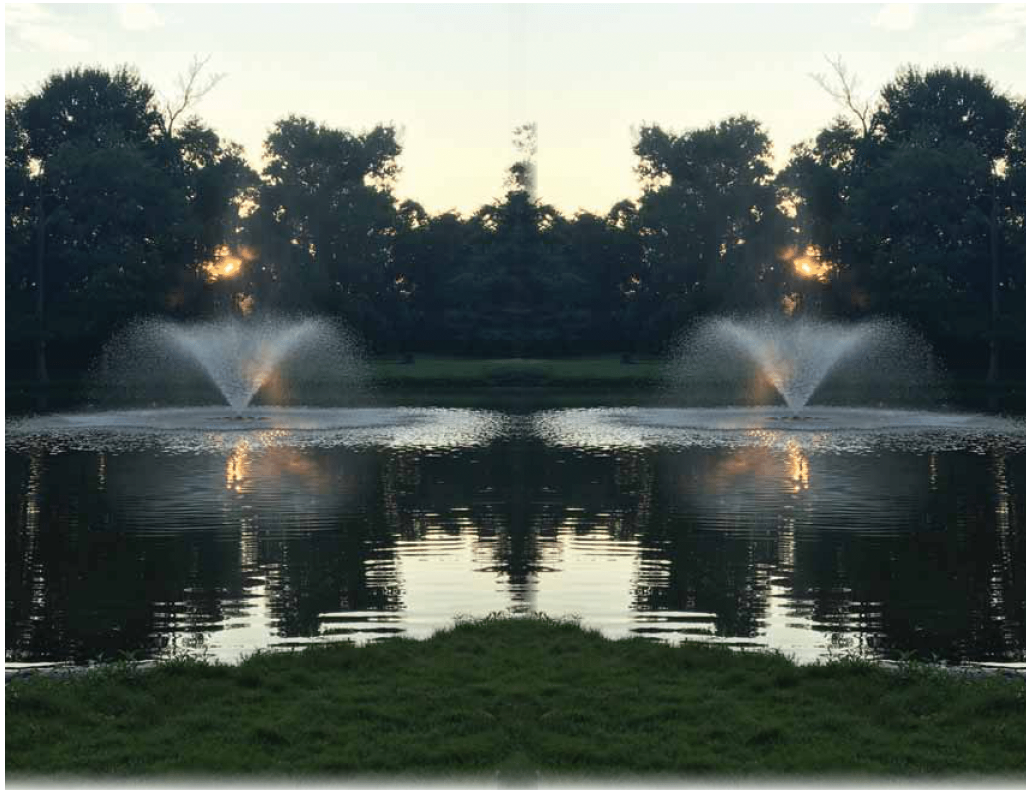

BRINGING WATER TO LIFE

Floating Fountains

- Masters Series®
- Masters Decorative Series
- Masters Grand® Series
- Galaxy Select® Series

Lighting and Accessories

- Night Glow Lighting and Control Panels
- LED or RGBW Lighting System

High Performance Aeration Systems

- Volcano II Surface Spray Systems
- Volcano III Surface Spray Systems
- AquaAir® Ultra Aeration Systems

Fixed Base Water Feature Fountains

- Custom Horizontal and Vertical Models

Land Master® Landscape Lighting

- LED or RGBW Lighting System